

Accelerometer (Industrial) with built-in temperature sensor

VIB 6.163

Installation and Operation



Sensors of series VIB 6.163 are used in industry to measure the following parameters:

- Vibration acceleration on rotating machines
- Cavitation in pumps
- Shock pulse signals in roller bearings
- Temperature of the measurement location

Safety instructions

- Read these operating instructions carefully and keep them in a safe place.
- Observe the operating instructions of the devices to be connected.
- Only use the sensors as intended and only for the permitted purpose of application.
- Only use original accessories.
- Replace defective sensors and cables.
- Have installation carried out by qualified personnel exclusively.
- Comply with the applicable safety regulations when performing installation tasks on the machine in operation.
- Lay the cables in accordance with the applicable safety regulations.
- Observe the technical specifications and permissible operating conditions. If in doubt, contact PRUFTECHNIK.
- The sensors are compliant with the applicable European directives. The complete Declaration of Conformity is available under www.pruftechnik.com/certificates.

Maintenance and repair work

Operation of the sensors does not require any maintenance. Repair work is not possible.

Accessories

- Sensor cable with 4-pole M12x1 plug-in connector, straight, partly pre-assembled, PUR sheath, 10 m, Item no.: VIB 6.164-10.
- Bonded adapter, Item no.: VIB 3.431

Storage

The following instructions are to be observed in relation to temporary storage of the sensors prior to installation:

- Store the sensors in the original packaging.
- Conditions at the storage location:
 - Dry and free of dust
 - Temperatures are within the permissible range
 - Vibration-free
 - No high electromagnetic fields
 - No corrosive materials

Disposal

After use, dispose of the sensors in an environmentally friendly manner and in accordance with national provisions.



pruftechnik.com/certificates

Technical data

PARAMETER		VIB 6.163
Vibration	Signaling system	Current Line Drive (CLD)
	Transmission factor (Ref.: 159 Hz; 25 °C [77°F])	1.0 $\mu\text{A}/\text{ms}^{-2}$ [9.8 $\mu\text{A}/\text{g}$] \pm 2%
	Frequency range \pm 3dB	0.8Hz ... 20kHz
	Resonance frequency	26 kHz
	Linearity range \pm 10%	\pm 961 ms^{-2} [\pm 98g]
Temperature	Measurement range	-20 °C ...+100 °C [-4 °F ... + 212 °F]
	Transmission factor \pm 3%	10 mV/K
	Offset	750 mV at 25 °C
Electrical	Operating voltage	8-12 VDC (from current loop)
	Carrier current	3.5 mA \pm 0.2 mA DC
	Electrical noise	< 0.004 ms^{-2} at 1 Hz
	Output impedance	> 1.6 MOhm
Environment / Mechanical	Protection class	IP 67 with cable connector locked
	Shock limit	< 250 kms^{-2}
	Case material	Stainless steel VA 1.4305
	Weight	62 g [2,2 oz]
	Cable connection	M12 connector, 4-pin
	Mounting thread	M8, 90° cone
	Mounting height	> 110 mm [4 5/16"]

Frequency response

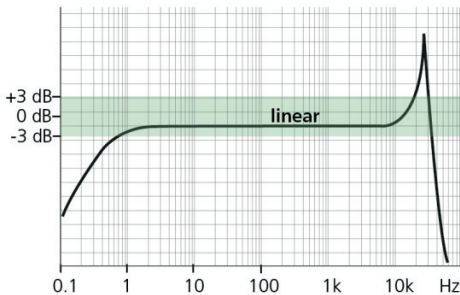

Sensor pin allocation



Pin	Signal
1	GND (shield)
2	GND
3	Vibration
4	Temperature

Installation

The frequency behavior and dynamic range of the sensor can be heavily influenced by installation. Poor coupling with the measurement location dampens the signal and restricts the frequency range. As a general rule, the sensor requires firm, friction-locked, contact and resonance-free attachment to the measurement location. This particularly applies to measurements at high frequencies.

Basically, the following applies:

$$10 \times \text{Weight}_{\text{Sensor}} < \text{Weight}_{\text{object to be measured}}$$

The stabilized coupling can be achieved by **screw-
ing** the sensor onto the measurement location. If screw mounting is not possible or inadmissible, the sensor can be attached with an **adhesive** adapter.

Screw mounting

Required tools and resources

- Hand-held drill
- Drill bits (4.2 mm / 6.8 mm) with depth gage ring
- 90° countersink bit (VIB 8.694)
- M8 thread tap
- Torque wrench with 19 mm / 3/4" hex socket
- Compressed air for cleaning out the hole
- Solvent for degreasing
- Threadlocker (LOCTITE 243)

Select the point of installation

- The drilled hole must have direct connection to the bearing carrier if the sensor should measure shock pulse signals.
- Minimum distance between the drilled hole and protruding edges of the housing must be 35 mm (A). Allow adequate clearance to attach the wrench.

Note

Ensure that a hole can be drilled at the chosen location.

Drill threaded hole M8 / 90°

- Drill pilot hole: 3.5 mm / 15 mm deep (B).
- Bore out hole: 6.8 mm / 15 mm deep (C).
- Countersink hole: 90° / 3 mm deep (D).
- Blow out the hole.
- Grease thread tap.
- Tap thread: M8 / 12 mm deep (E).
- Blow out the hole.

Mount sensor

- Clean the contact surfaces of the sensor and the machine with solvent.
- Allow contact surfaces to dry.
- Thinly apply LOCTITE 243 to improve signal transmission.
- Screw in the sensor and tighten with a torque wrench (11 Nm, F).
- Check the sensor for tight mechanical fit.

Notes

Excessive torque can damage the thread or the machine housing. Too little torque can allow the sensor to work loose. Incorrect torque always causes measurement errors!

The sensor must be protected against static charging if it is installed on a non-grounded machine (e.g. belt-driven fan).

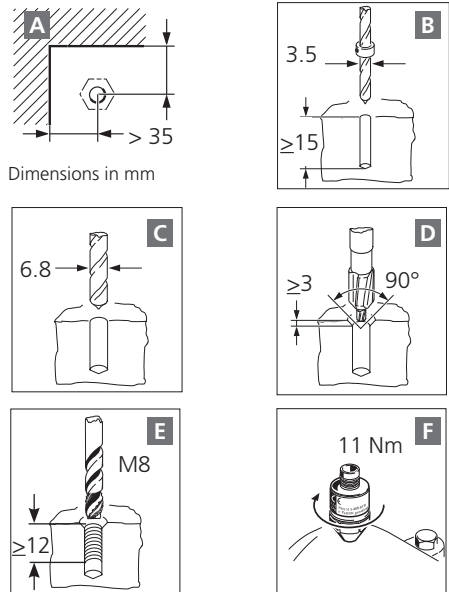

Adhesive mounting

Applies to sensor of series VIB 6.163 and mounting adapter VIB 3.431.

Required tools and resources

- Hand-held drill and drill bit (3.5 mm)
- Angle grinder and rasp
- Torque wrench with 19 mm / 3/4" hex socket
- Compressed air for cleaning out the hole.
- Solvent for degreasing
- Threadlocker (LOCTITE 243)
- 2-Component adhesive (WEICON HB 300,...)

Note

Switch off the machine and secure it against a restart. Do not switch on the machine until the adhesive has hardened (approx. 24 hours).

Follow the instructions for use of the adhesive.

Select the point of installation

- The point of installation must have direct connection to the bearing carrier if the sensor should measure shock pulse signals.
- The possible temperatures at the point of installation must not exceed the application temperature range of the adhesive.
- Allow sufficient space for applying the adhesive with a wooden spatula.

Prepare bonding location

- Grind down existing coats to the bare metal ($\varnothing > 30$ mm, **G**).
- If necessary, grind down the location (**G**).
- Sand down the point of installation with a rasp and file several grooves in a diamond pattern for greater adhesive strength (**G**).

Optionally, and only if drilling is possible:

- Drill hole for centering pin: 3.6 mm / 5 mm deep (**H**). Remove the centering pin from the mounting adapter if drilling is not possible.
- Blow out the hole.
- Clean the contact surfaces of the mounting adapter and the machine with solvent.
- Allow contact surfaces to dry.

Apply adhesive

- Prepare the adhesive for use.
- Apply the adhesive with a wooden spatula evenly to the base of the mounting adapter and the bonding location (approx. 1 mm thick, **I**).

Affix mounting adapter

- Press the adapter gently against the bonding location and turn it to evenly distribute the adhesive. If applicable, screw in the centering pin (**J**).
- Do not remove excess adhesive. If necessary, apply additional adhesive around the bonding location for greater stability.
- If necessary, use adhesive tape to hold the adapter in place during hardening.

Mount sensor

- Clean the contact surfaces of the sensor and the adapter with solvent.
- Allow contact surfaces to dry.
- Thinly apply LOCTITE 243 to improve signal transmission.
- Screw in the sensor and tighten with a torque wrench (3 Nm, **F**).
- Check the sensor for tight mechanical fit.

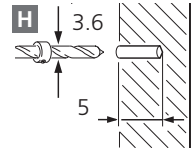
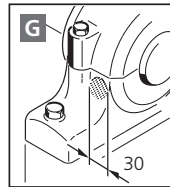

Dimensions in mm

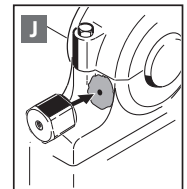
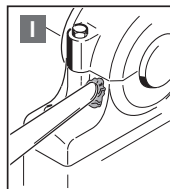

Electrical connection

The signal is transmitted via a coaxial cable. On the sensor side, the cable is assembled with a TNC plug and, if necessary, equipped with protective caps. The other end of the cable is either equipped with a measuring device plug or open for the terminal connection in a stationary signal evaluation device.

Cable specification

- Sheath PUR, black
- Diameter D 5.1 mm
- Bending radius 5x D (fixed); 12 x D (movable)
- Connector plug M12x1
- Special charact. Flame-resistant, seawater-resistant, acid-resistant, alkali-resistant, ozone-resistant, UV-resistant, can be used in drag chain, halogen-free, silicone-free, oil-resistant
- Wire color code:

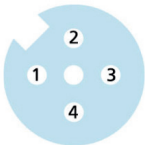

Wire	Color
1	BN - brown
2	WH - white
3	BU - blue
4	BK - black

Note

Shielded line in the connector not laid.

Connect the sensor

- Screw the M12 connector on the sensor and tighten by hand.

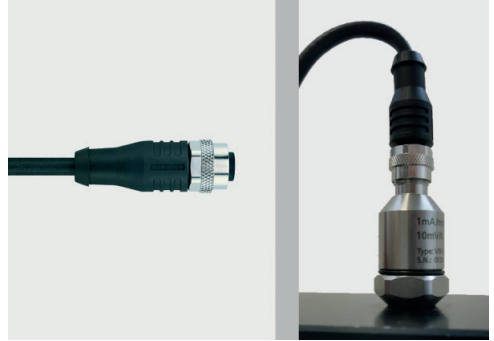

Lay the cable

- Have the electrical connection established by a qualified electrician exclusively.
- Observe the regulations for setting up electrical systems.
- Do not kink, pinch, knot, twist or mechanically overload the cables.
- It is preferable to lay the cable in a cable duct or protective tube.
- Use cable ties and Velcro fasteners to fix the cables in place.
- Do not lay cables parallel to power lines. Adhere to the minimum spacing (> 1 m).
- Lay a loop with sufficient reserve traction ahead of a cable gland.
- Label the cable ends to avoid getting them mixed up

Extend the cable

- Observe the maximum cable lengths (see the device installation manual).
- Use shielded, 4-wire electrical cables for extension.
- Connect the cable ends in a junction box.
- Mount a metal junction box electrically insulated.



LIT 61.202.EN
08.2018

 **PRÜFTECHNIK**

PRÜFTECHNIK
85737 Ismaning, Germany
www.pruftechnik.com

Productive maintenance technology